

Pioneering for You

wilo

Product brochure

Wastewater transport and drainage – Customized pump solutions.

Wilo-EMU FA



With SOLID
impellers and
IE3 motors

Making the Wilo-EMU FA your own.

Ready for your application.

Wilo's solution: the Wilo-EMU FA submersible sewage pump. From drainage to sewage transport, we've got you covered. A wide range of hydraulics and motor combinations allow you to adjust the pump's output specifically to meet your needs. A Wilo-Ceram coating can increase resistance to abrasive or corrosive fluids over a standard coating. The Wilo-EMU FA - Bringing reliable pumping across all applications.

Overview of advantages:

- Selections for your conditions
- Reliable operation and durable construction
- Reduced maintenance and operating costs
- Various Ex-ratings available (e.g. ATEX, FM, CSA)
- Suitable for continuous duty and submersion

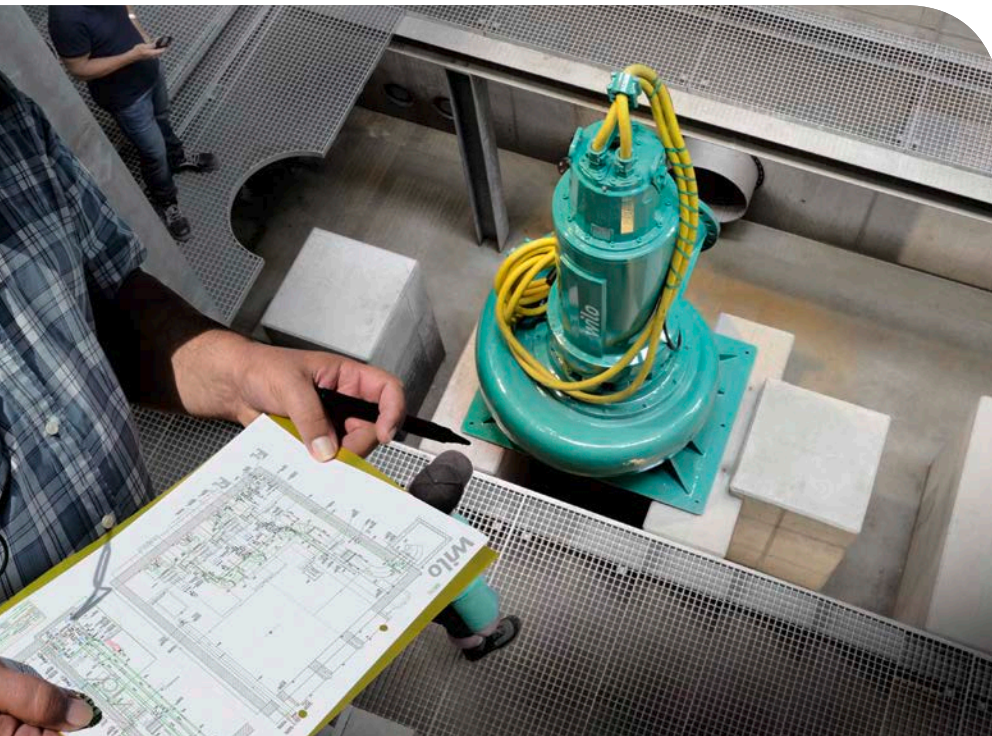

Monitored and assured efficiency according to plan. Optimally solved with the Wilo-EMU FA.

Features & Benefits

- Various Ex-ratings available (FM, CSA, ATEX)
- Customized to meet your specific requirements
- Reduced maintenance & operating costs
- Minimized impeller overhang for durability as well as long seal & bearing life
- Suitable for Wet/Dry pit, and continuous duty applications

Sophisticated motor technology

- Efficient motor technology for surface-cooled and self-cooling motors
- Suitable for submerged and non-submerged applications
- Extreme operating reliability due to a diverse range of monitoring options (e.g. motor winding, sealing chamber, motor bearing)
- Optionally with energy-efficient IE3 motor technology
- Variety of seal variants available

Coatings and special materials

- Explosion-Proof Certification (FM)
- Inverter duty-compliant
- Coated with high-quality 2-component paint as standard
- For corrosive fluids, the external surfaces can be coated with Wilo-Ceram C0
- Various construction materials for highly aggressive fluids available on request

Variety of impeller variants

- Different impeller shapes for optimum pumping of different fluids
- Hydraulic pump output optimally adapted to the desired duty point
- For abrasive fluids, the internal surfaces can be coated with Wilo-Ceram C1-C3

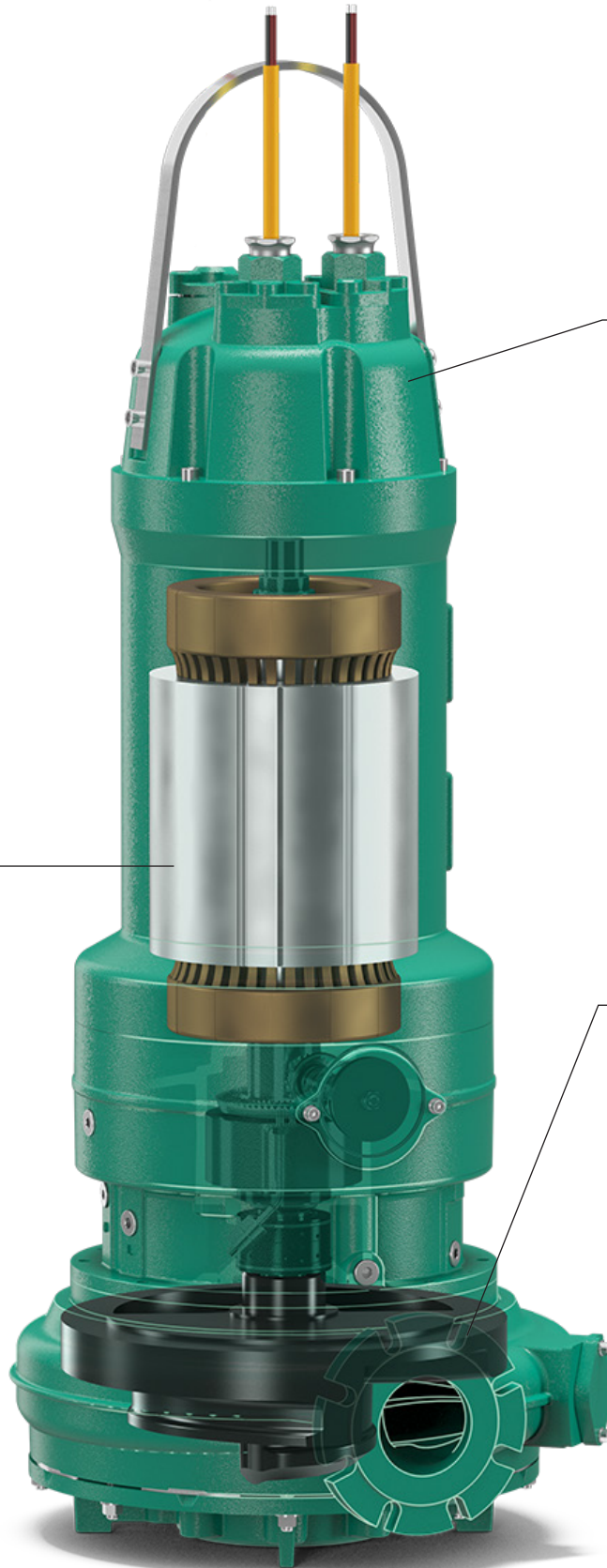

Wilo-EMU FA with SOLID-G impeller and FKT motor technology

Wilo-EMU FA.

The right impeller for practically any fluid.

Whether untreated sewage, pre-treated sewage or wastewater – optimum transport of different fluids requires the appropriate impeller. No single requirement is like another, so we carry a large number of impeller designs in our range – from the vortex impeller through to multi-channel impellers and the SOLID impeller.

This means you can select an impeller for your Wilo-EMU FA that is adapted to your system and takes account of individual situations such as inflow conditions, delivery head and the type of fluid. The result is that you can count on efficient and reliable pumping operations. Irrespective of the composition of the fluid.

Comparison of efficiency and anti-clogging properties of the impellers.

When it comes to the hydraulic selection, it is necessary to consider the specific factors of the system such as inflow conditions, fluid composition or volume. During system optimisation, the aim is to find the best compromise between efficiency and process reliability.

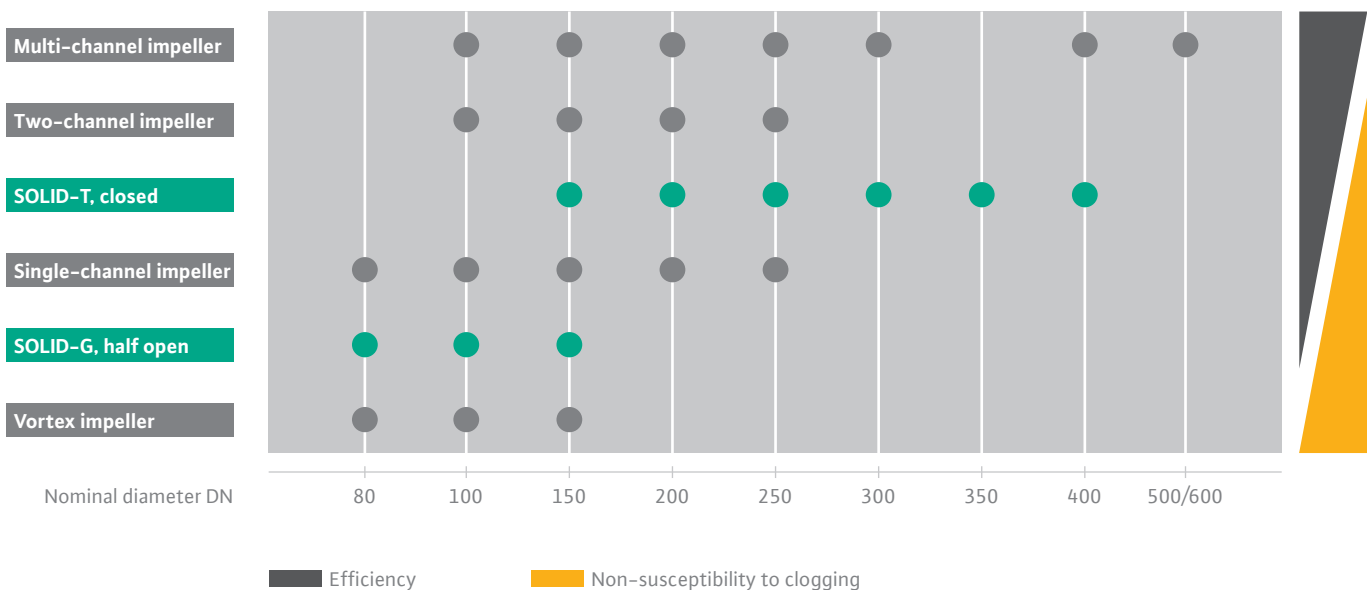

Subject to change without prior notice.

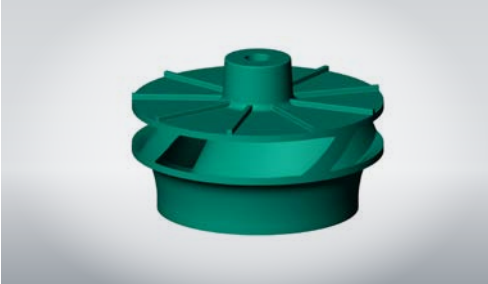

Closed multi-channel impellers (two, three, four-channel impellers)

- Pre-treated sewage
- Wastewater
- Activated and digested sludge

Technical data:*

Max. Flow: 3,800 gpm
 Max. Head: 394 ft
 Free ball passage: 2 – 6.7 in



Closed SOLID-T impeller

- Untreated sewage
- Pre-treated sewage
- Activated and digested sludge

Technical data:*

Max. Flow: 1,200 gpm
 Max. Head: 170 ft
 Free ball passage: 3 – 6.7 in

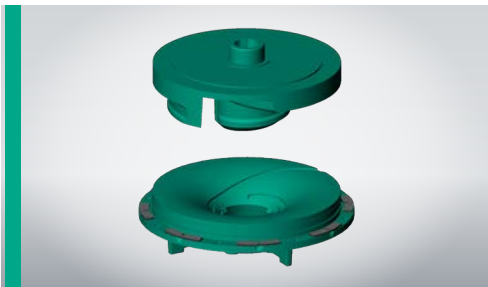

Half open SOLID-G impeller

- Untreated sewage
- Pre-treated sewage
- Activated and digested sludge

Technical data:*

Max. Flow: 1,360 gpm
 Max. Head: 127 ft
 Free ball passage: 3 – 3.5 in

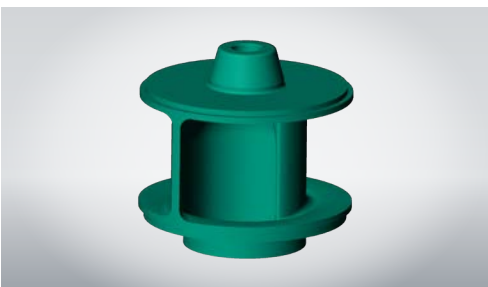

Closed single-channel impellers

- Untreated sewage**
- Pre-treated sewage
- Activated and digested sludge

Technical data:*

Max. Flow: 5,090 gpm
 Max. Head: 187 ft
 Free ball passage: 1.7 – 7.9 in

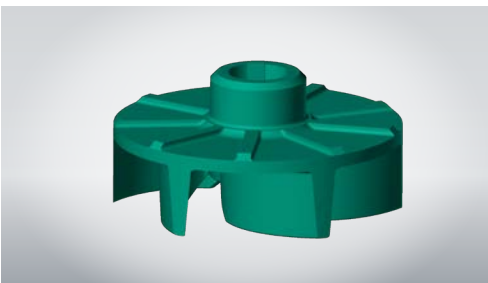

Vortex impeller

- Untreated sewage
- Pre-treated sewage
- Wastewater
- Activated and digested sludge
- Fluids with coarse constituents

Technical data:*

Max. Flow: 2,200 gpm
 Max. Head: 283 ft
 Free ball passage: 1.4 – 5.1 in

*Technical data based on a 60 Hz mains connection.

**Depending on the free ball passage.

The SOLID series.

Your impellers for heavily contaminated wastewater.

The higher the solids content of the fluid, the higher the risk of clogging. This represents a greater risk of disruptions in operation. In extreme cases, this can also mean higher service costs for you as the end-user. The solution is impeller technology with low susceptibility to clogging and high efficiency, especially for untreated sewage: SOLIDS. The impellers ensure greater operational reliability at the same time as reducing operating costs. Two SOLID variants are available— each of them is a high-performance, individual solution with high efficiency.



SOLID impeller technology. Reliable, low susceptibility to clogging and high efficiency.

The half open SOLID-G impeller.

Your choice for when you need to pump untreated sewage with an effective combination of consistently high efficiency and non-susceptibility to clogging – even when operated with partial loads and with long-fiber constituents. Adjustable suction port and reinforced blade edges on the pressure side ensure long-lasting efficiency and durability.

The closed SOLID-T impeller.

Excellent suited to pumping untreated sewage reliably and extremely efficient. The impeller has large passage dimensions for particularly high efficiency. It runs particularly smoothly and with low vibration thanks to the optimised impeller geometry. The homogeneous flow course contributes to operational reliability.

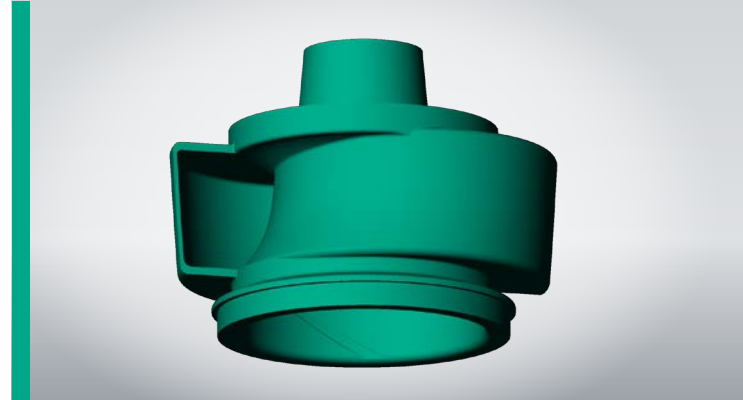
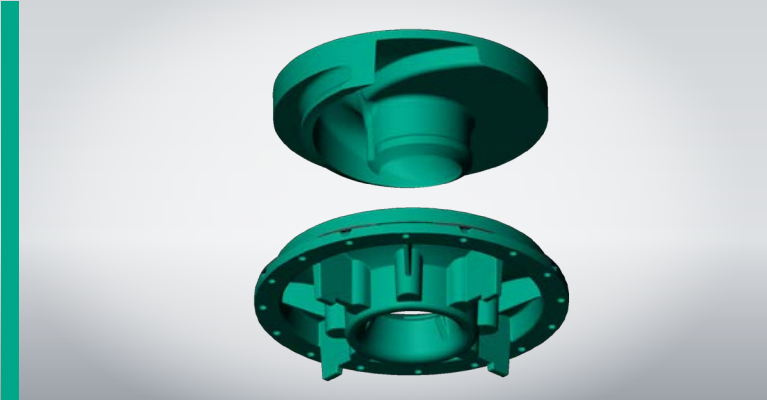

Overview of the advantages:

- Excellent operational reliability, even with untreated sewage
- Reduced energy costs in comparison to existing vortex impellers
- The perfect blend of efficiency and operational reliability
- Low maintenance costs thanks to non-susceptibility to clogging – even when operated with partial loads

A comparison between the overall costs makes it clear: A Wilo-EMU FA with SOLID-T impeller offers convincingly high efficiency paired with low energy costs, making it an efficient solution.

Wilo-EMU FA with SOLID impeller – economic comparison			
	Wilo-EMU FA 15.95E-362 + FKT 27.1-6/22K	Wilo-EMU FA 15.44W-328 + FKT 27.1-4/28K	Wilo-EMU FA 15.95T-311 FKT 27.1-6/22K
Activation type	Direct	Direct	Direct
Running time per day	10 h	10 h	10 h
Free passage	4.33 in	5.12 in	3.07x4.13 in
Volume flow	1270 gpm	1270 gpm	1270 gpm
Delivery head	52.5 ft	52.5 ft	52.5 ft
Motor power	28.5 hp	56 hp	27.5 hp
Number of poles	6	4	6
	Single-channel impeller	Vortex impeller	Shut SOLID-T impeller
Acquisition costs*	\$ 38,955.00	\$ 34,071.00	\$ 38,955.00
Energy costs per year	\$ 9,417.00	\$ 17,739.00	\$ 8,979.00
Downtime and service costs per year**	\$ 2,000.00	\$ 500.00	\$ 1,000.00
Total costs in five years***	\$ 96,040.00	\$ 125,266.00	\$ 88,850.00

* Gross list prices.

** Estimate based on field test installations at \$ 250.00 per service callout.

*** Energy costs calculated at a constant rate of \$ 0.12/kWh.

Sewage pumps set up dry for 2-pump system for untreated sewage

Cost saving
of approx.
\$ 36,416.00

Wilo-EMU FA.

Efficient motors are what drives you.

The right motor is just as important as selecting the right hydraulics for the job. Wilo has a wide range of surface-cooled and self-cooling motors, for your installation type. Several seal types are available as well to handle the fluid type.

Seal variants.

Operational reliability, double-protected.

Whenever fluid enters the motor compartment, it will lead to a breakdown. To prevent this, there is a seal housing between the hydraulics and motor which is provided with seals on the motor and pump sides as well as a sealing and leakage chamber.

The requirements on the seal increase with the solid matter content and the proportion of long-fiber constituents in the fluid. As a result, the seals on the motor and pump sides can be made in up to three different ways:

- Standard seal for normal loads. A mechanical seal on the fluid side, a rotary shaft seal on the motor side made of NBR or FPM.
- High-quality seal for high loads provided by two independently rotating mechanical seals.
- Extreme loads are handled two independently rotating mechanical SiC seals, fitted in a stainless steel cartridge.



The Wilo-EMU FA: Excellently suited to wet and dry well installation



Monitoring devices

- Winding monitoring
- Motor/terminal compartment monitoring
- Sealing chamber control
- Leakage chamber monitoring
- Bearing temperature monitoring

Power efficiently put into practice – with IE3 as well

The higher the efficiency of a motor, the less energy it needs. In addition to the standard motors, you are also able to select highly efficient motors with energy efficiency class IE3 (derived from IEC 60034-30) for your Wilo-EMU FA system. Your increased level of efficiency means you can save up to 5% of your energy costs per year. Thanks to being based on the same design as the standard motors, they can be used with almost all hydraulics, and what is more they are Ex-rated.

Surface-cooled or self-cooling design? It comes down to the installation.

If you are planning a wet well installation in pump chambers, you would be well advised to choose surface-cooled motors. They can be operated immersed in continuous duty and non-immersed in short-time duty. The surface-cooled motors are cooled by the surrounding fluid.

Self-cooling motors are recommended for dry well installation, because they can be used immersed and non-immersed in continuous duty. An internal, active cooling system provides the necessary cooling of the powerful drive. The waste heat is dissipated to the heat exchanger by the coolant. This outputs the waste heat to the fluid.

The Ceram coating by Wilo.

Effective protection from abrasion and corrosion.

The unique 2-component coating based on a polymer/aluminium oxide composite material offers the best possible protection against aggressive media compared to other coatings. Thanks to its increased resistance to corrosion and abrasion, it effectively prevents wear and chemical corrosion and always ensures optimum functionality and performance. Wilo-Ceram significantly enhances the service life of sewage pumps.



Versatile.

The protective coating permits application even in seawater, brackish water and industrial applications.

Overview of advantages:

- Corrosion-resistant thanks to excellent wet adhesion
- Abrasion-resistant thanks to high proportion of aluminium oxide constituents
- Reliable even in seawater, brackish water and industrial applications
- Can be combined freely with individual Ceram variants for special media



Reliable protection. Exclusively from Wilo.

The Wilo-Ceram coating is exclusively available for pumps and units from Wilo. This gives you a double reassurance. First, knowing that you have selected a tailor-made product. Second, being able to use durable technology which what is more, offers a long service life and reduced down times. It is available in four different versions.

Overview of Wilo-Ceram coatings				
	Ceram C0	Ceram C1	Ceram C2	Ceram C3
Technical data				
Protection against	Corrosion	Corrosion	Abrasion	Abrasion
Processing	Can be sprayed	Can be sprayed	Solid	Solid
Coat thickness	0.4 mm	0.8 mm	1.5 mm	3 mm
Use				
Motor housing, external	•	—	—	—
Hydraulics housing, external	•	—	—	—
Hydraulics housing, internal	•	•	•	•
Impeller	•	•	•	—

The Ceram coating from Wilo offers comprehensive protection for the most important components of the Wilo-EMU FA submersible sewage pump.

Resistance for Ceram C0 by Wilo		
Designation	Temperature range	Resistance
Sewage, alkaline (pH 11)	+68°F/+104°F	1/1
Sewage, slightly acidic (pH 6)	+68°F/+104°F	1/1
Sewage, highly acidic (pH 1)	+68°F/+104°F	2/3
Ammonium hydroxide (5%)	+104°F	3
Decanol (fatty alcohol)	+68°F/+122°F	1/1
Ethanol (40%)	+104°F	1
Ethanol (96%)	+104°F	3
Ethylene glycol	+104°F	1
Heating oil, diesel	+104°F	1
Compressor oil	+104°F	1
Methyl ethyl ketone (MEK)	+104°F	3
Caustic soda (5%)	+68°F/+122°F	1/2
Sodium chloride solution (10%)	+104°F	1
Hydrochloric acid (5/10/20%)	+104°F	2/2/3
Sulphuric acid (10/20%)	+104°F	2/3
Nitric acid (5%)	+104°F	3
Toluene	+104°F	2
Cooling and industrial water	+104°F	1
Xylene	+104°F	1

Additional stability lists for Ceram C1, C2 and C3 as well as the technical data of the individual Ceram varieties can be found at www.wilo.com/en/watermanagement

1 = resistant, 2 = 40 day-resistant, 3 = overflow-resistant (immediate cleaning recommended)
For an overall layer thickness of min. 400 µm



www.wilo-usa.com

WILO USA LLC
+1 (262) 204-6600
www.wilo-usa.com
info.us@wilo.com

WILO Canada Inc.
+1 (403) 276-9456
www.wilo-canada.com
info@wilo-canada.com

Pioneering for You